

# AREBOS

## Mini Heat Pump

AR-HE-WP

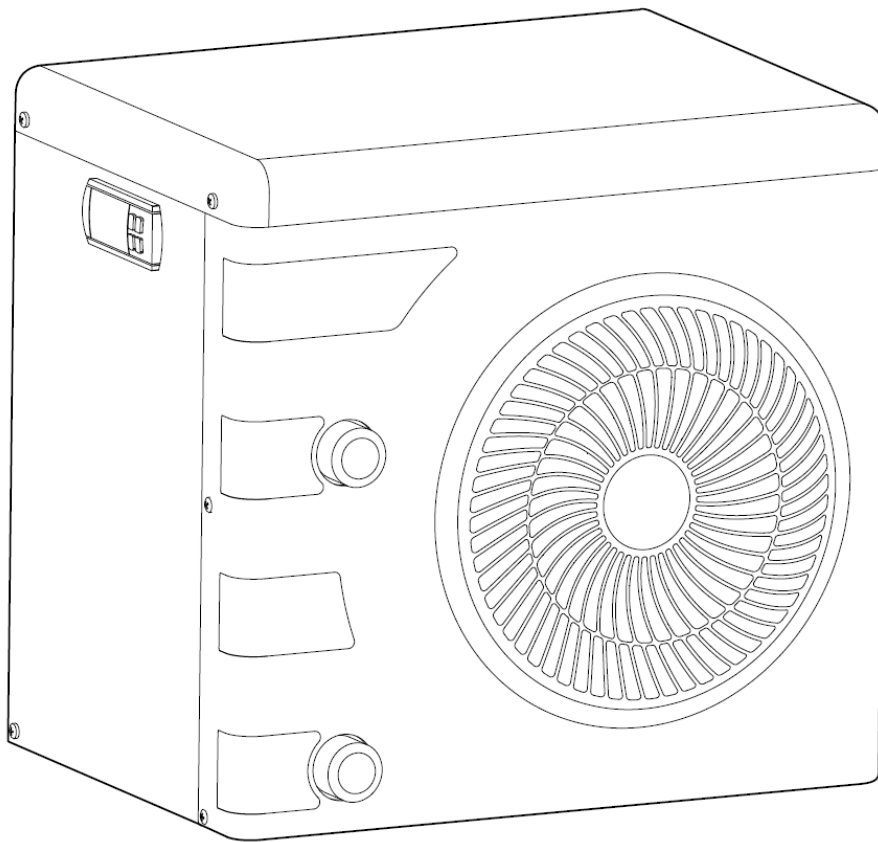

Please follow all security measures in this user's manual to ensure a secure use.



Thank you for trusting in AREBOS.

# Table of Contents

<b>1</b>	<b>Introduction and safety instructions.....</b>	<b>3</b>
<b>2</b>	<b>Description .....</b>	<b>6</b>
<b>3</b>	<b>Transport information .....</b>	<b>7</b>
<b>4</b>	<b>Start-up of the Heat Pump.....</b>	<b>8</b>
<b>5</b>	<b>Location and connection.....</b>	<b>9</b>
<b>6</b>	<b>Electrical Wiring .....</b>	<b>12</b>
<b>7</b>	<b>Specifications .....</b>	<b>13</b>
<b>8</b>	<b>Accessories &amp; fitting .....</b>	<b>14</b>
<b>9</b>	<b>Troubleshooting .....</b>	<b>14</b>
<b>10</b>	<b>Exploded Diagram .....</b>	<b>15</b>
<b>11</b>	<b>Maintenance .....</b>	<b>15</b>
<b>12</b>	<b>Service manual .....</b>	<b>16</b>
<b>13</b>	<b>Environmentally friendly disposal .....</b>	<b>23</b>
	<b>EU Declaration of Conformity .....</b>	<b>24</b>

Thank you for purchasing our product. Please read the operating instructions carefully before using the product for the first time. If you give the product to a third party, this manual must be handed over with it. Keep the instruction manual for future reference. The drawings in this manual may not match the physical objects. Please refer to the physical objects.

# 1 Introduction and safety instructions

## Introduction

- This instruction handbook is intended to familiarise you with the installation, use and maintenance of the product. To install the unit safely and correctly, please read the operating instructions **before** you start.

## Explanation of the symbols



By means of a CE marking, it can be recognized that a product complies with the legal requirements of European legal standards and therefore may be traded within the European Community.



**Warning!** Read the safety instructions carefully. Failure to follow the safety precautions could result in serious injury or damage. Keep the operating instructions in a safe place.



**Attention!** Make sure the product is grounded!



**Note!** Pull out the mains plug.



Use with caution when using this article!



**Warning!** Risk of electrical voltage!



**Warning!** Flammable material, flammable substances!

 **WARNING!** This signal symbol/word indicates a hazard with a medium level of risk which, if not avoided, may result in death or serious injury. injury if not avoided.

 **CAUTION! / ATTENTION!** This signal symbol/word indicates a hazard with a low level of risk which, if not avoided, may result in a minor or moderate injury. injury if not avoided.

**Note!** This signal symbol/word warns you of possible property damage.



This product **must not** be disposed of with household waste!

Thank you for using this mini pool heat pump for your pool heating, it will heat your pool water and keep the constant temperature when the air ambient temperature is at 9 to 40°C and the pool water temperature is at 9 to 40°C.

This appliance is intended to be used by expert or trained users in shops, in light industry and on farms, or for commercial use by lay persons.

### Electrical protection

The power supply for the heat pump must come, preferably, from an exclusive circuit with regulatory protection components (30mA differential protection) and a magneto-thermal switch.

- The electrical installation must be carried out by a specialized professional (electrician) in accordance with the standards and regulations in force in the country of installation.
- The heat pump circuit must be connected to a safety earth circuit at the terminal block.
- The cables must be properly installed to prevent interference. If damaged, it must be replaced by the manufacturer, its service agent or similarly qualified persons in order to avoid a hazard.
- The pump is intended for connection to a general power supply with earth connection.
- Section of the cable; This section is indicative and should be checked and adapted according to the needs and conditions of use.
- The tolerance of acceptable voltage variation is +/- 10% during operation.

The connections must be dimensioned according to the power of the device and the state of installation.

Models	Circuit breaker	Maximum length of the wire			
		1,5 mm <sup>2</sup>	4 mm <sup>2</sup>	6 mm <sup>2</sup>	10 mm <sup>2</sup>
AR-HE-WP	10 A	84 m	135 m	200 m	335 m



**These values are given as a guideline, only the intervention of an authorized technician can determine the values corresponding to your installation.  
The electric line must be equipped with a ground connection and with a circuit breaker with difference 30mA in head.**



### ATTENTION:

- This manual includes all the necessary information with the use and the installation of your heat pump.
- The installer must read the manual attentively and follow the instructions in implementation and maintenance.
- The installer is responsible for the installation of the product and should follow all the instructions of the manufacturer and the regulations in application. Incorrect installation against the manual implies the exclusion of the entire guarantee.
- The manufacturer declines any responsibility for the damage caused with the people, objects and of the errors due to the installation that disobey the manual guideline. Any use that is without conformity at the origin of its manufacturing will be regarded as dangerous.

**⚠ WARNING:**

- Please always empty the water in heat pump during winter time or when the ambient temperature drops below 8°C, or else the Titanium exchanger will be damaged because of being frozen, in such case, your warranty will be lost.
- Please always cut the power supply if you want to open the cabinet to reach inside the heat pump, because there is high voltage electricity inside.
- Please well keep the display controller in a dry area, or well close the insulation cover to protect the display controller from being damaged by humidity.

## 2 Description

### With your Heat Pump

- Water PVC connector diameter 32 - 38mm (pcs: 2)
- User and service manual
- 1.5melectric extension and socket with 30mA earth leakage protection
- Anti-vibration base (pcs: 4)

### Dimension

Model: AR-HE-WP

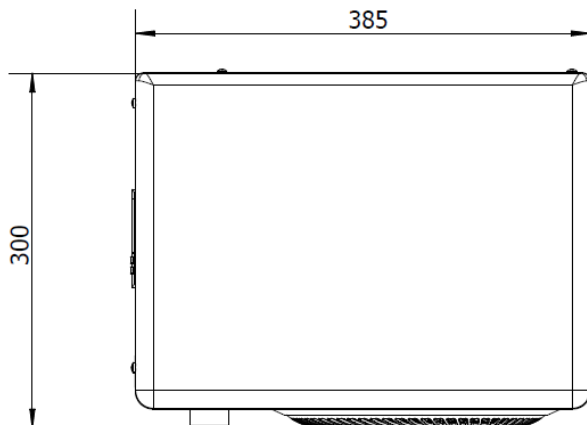
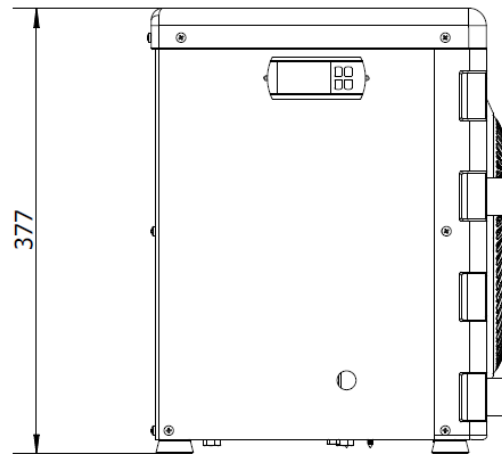
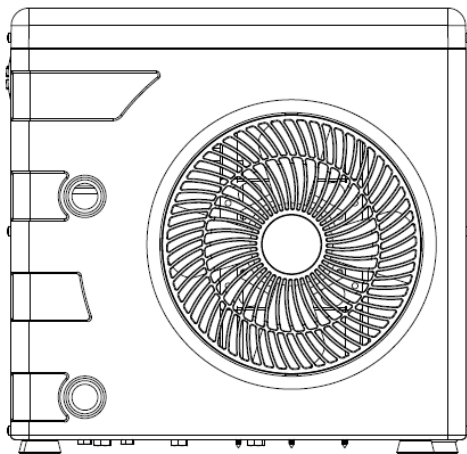

## 3 Transport information

### Delivery of the packaging



For the transportation, the heat pump is covered with a carton box. To preserve from any damage, the heat pump must be transfer on is pallet.

All material, even if the transport is chargeable to supplier, can be damaged during its routing at the customer and it is the responsibility of the addressee to make sure of the correspondence of the delivery. The addressee has to written all the reserves at the reception on the delivery note of the carrier if he notices damages of the packaging.

**DO NOT FORGET TO CONFIRM BY REGISTERED LETTER TO THE CARRIER UNDER 48 H.**

### Stock advice



Heat pump must be stored and transfer in vertical position in its original packaging. If it is not the case, she cannot be operated at once, a minimum period of 24H is necessary before to switch on the electrical power.

### FORBIDDEN





### Transfer to the final position

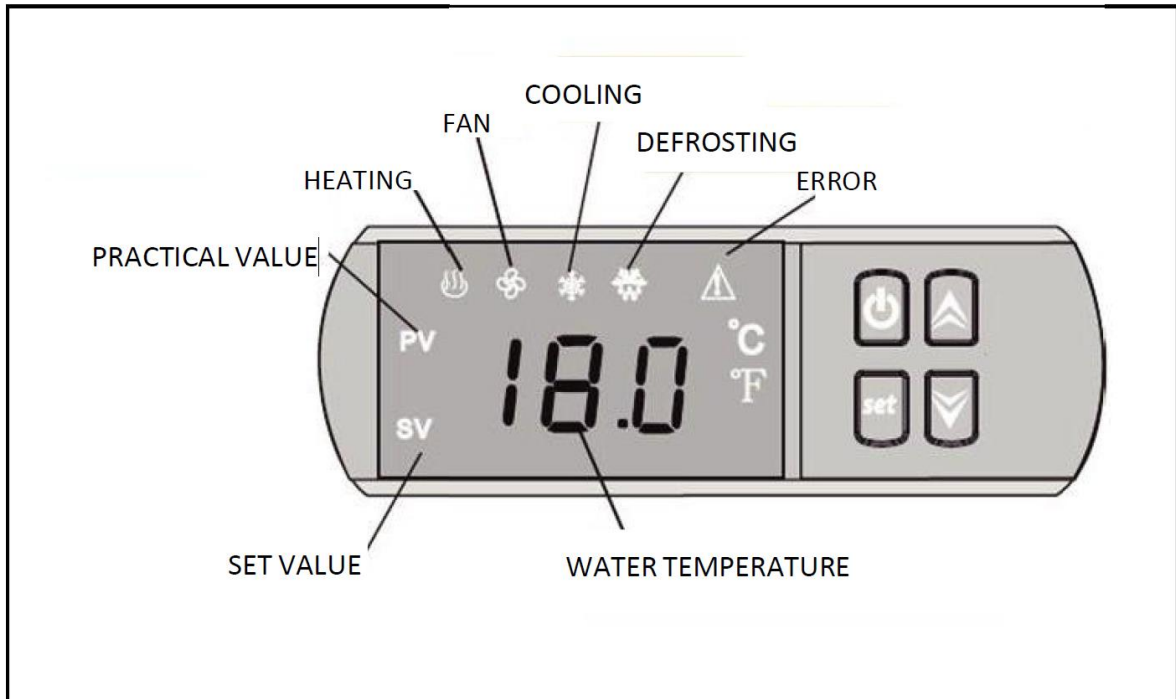

During the unpacking of the product and the transfer from is palette of origin to final place, it is necessary to maintain the heat pump vertical position.

Water connection are not there to assure the function of handle, on the contrary support the weight of the heat pump on the water connection must be damage definitively the product. The manufacturer could not be take the responsible in case of damage.





## 4 Start-up of the Heat Pump



1. ON/OFF : Press  for 2 seconds , start or stop the heat pump

2.  Long press  for 6 seconds, then press  or  to exchange C or F

**ATTENTION: THESE SETTING SHOULD SWEEP ALL THE PREVIOUS SETTING**

3. Water Temperature Setting: Press  once, "SV" lighting! Press  to up or press  down.
4. Press  to check the CT when the heat pump is running.
5. That the icon is flashing means preparing to work, and that the icon is lighting means working.
6. E1 or E2 means the sensor is not working please call the service.



## 5 Location and connection

### ATTENTION:

Please observe the following rules when installing the heat pump.

1. Any addition of chemicals must take place in the piping located downstream from the heat pump.
2. Always place the heat pump on a solid foundation and use the included rubber mounts to avoid vibration and noise.
3. Always hold the heat pump upright. If the unit has been held at an angle, wait at least 24 hours before starting the heat pump.
4. DO NOT place the unit next to shrubs which can block the air inlet. These locations deny the unit a continuous source of fresh air which reduces its efficiency and may prevent adequate heat delivery.

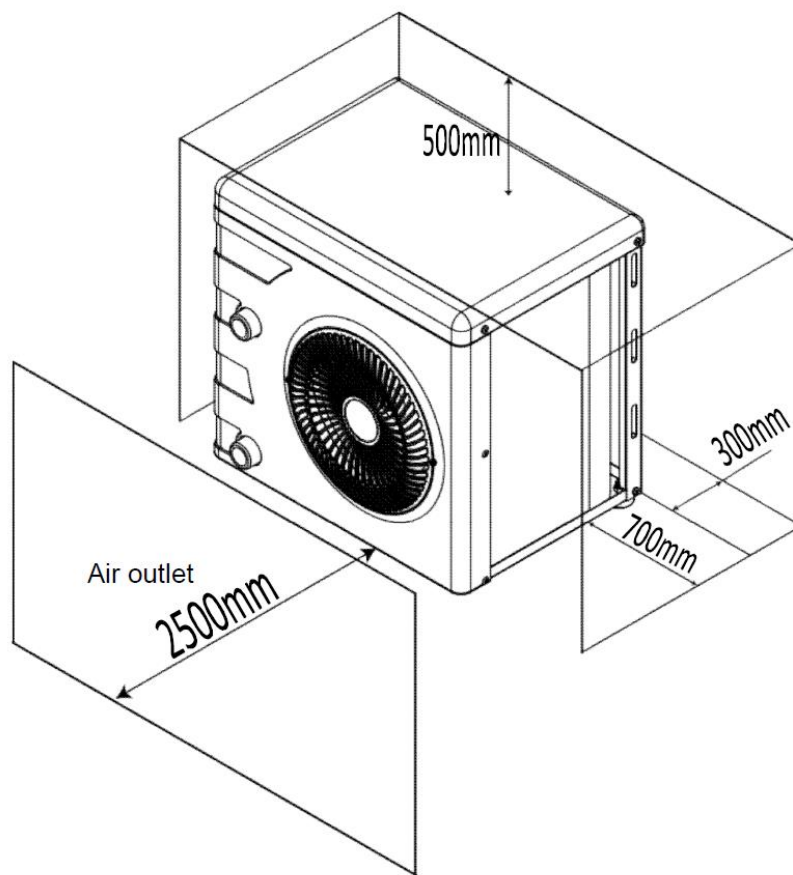

### Heat pump location

The unit will work properly in any desired location as long as the following three items are present:

1. **Fresh air**
2. **Electricity**
3. **Swimming pool filters**

The unit may be installed in virtually any **outdoor** location as long as the specified minimum distances to other objects are maintained (see drawing upon). Please consult your installer for installation with an indoor pool. Installation in a windy location does not present any problem at all, unlike the situation with a gas heater (including pilot flame problems).

**ATTENTION:** Never install the unit in a closed room with a limited air volume in which the air expelled from the unit will be reused, or close to shrubbery that could block the air inlet. Such locations impair the continuous supply of fresh air, resulting in reduced efficiency and possibly preventing sufficient heat output. See the drawing below for minimum dimensions.

The unit will work properly in any desired location as long as the following three items are present:

**Check-valve installation**

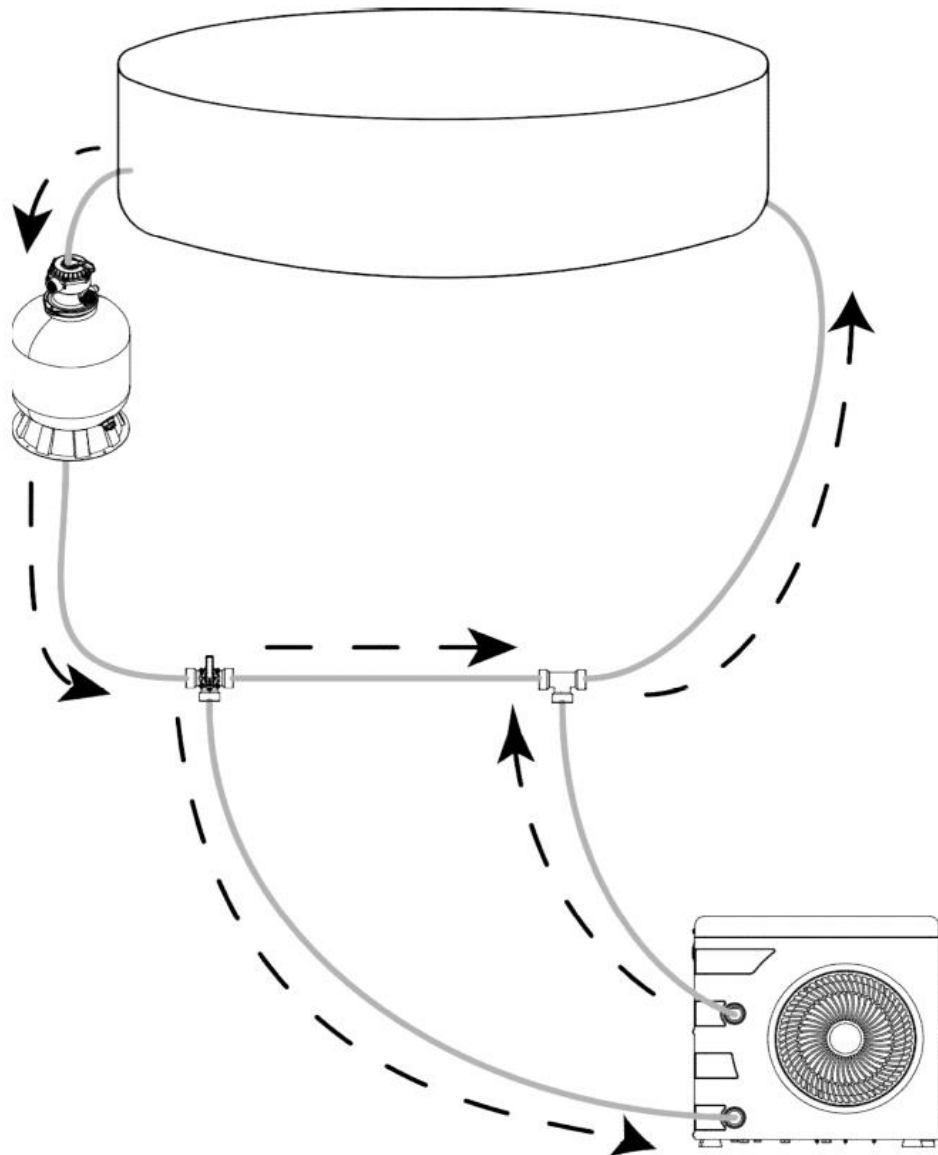

**⚠ NOTE:**

Note: If automatic dosing equipment for chlorine and acidity (pH) is used, it is essential to protect the heat pump against excessively high chemical concentrations which may corrode the heat exchanger. For this reason,

equipment of this sort must always be fitted in the piping on the downstream side of the heat pump, and it is recommended to install a check-valve to prevent reverse flow in the absence of water circulation.

Damage to the heat pump caused by failure to observe this instruction is not covered by the warranty.

 **NOTE:**

The factory supplies only the heat pump. All other components, including a bypass if necessary, must be provided by the user or the installer.

**ATTENTION:**

**In order to heat the water in the pool (or hot tub), the filter pump must be running to cause the water to circulate through the heat pump. The heat pump will not start up or be destroyed if the water is not circulating.**

**Initial operation**

After all connections, have been made and checked, carry out the following procedure:

1. Switch on the filter pump, check for leaks and verify that water is flowing from and to the swimming pool.
2. Connect power to the heat pump. The unit will start up after the time delay expires (see below).
3. After a few minutes, check whether the air blowing out of the unit is cooler.

Depending on the initial temperature of the water in the swimming pool and the air temperature, it may take several days to heat the water to the desired temperature. A good swimming pool cover can dramatically reduce the required length of time.

 **NOTE:**

**Time delay** - The heat pump has a built-in 3-minute start-up delay to protect the circuitry and avoid excessive contact wear. The unit will restart automatically after this time delay expires. Even a brief power interruption will trigger this time delay and prevent the unit from restarting immediately. Additional power interruptions during this delay period do not affect the 3-minute duration of the delay.

 **NOTE:**

The amount of condensation may be as much as several liters per hour at high relative humidity. This is sometimes mistakenly regarded as a water leak.

## 6 Electrical Wiring

### Mini pool heat pump wiring diagram Basic electrical wiring

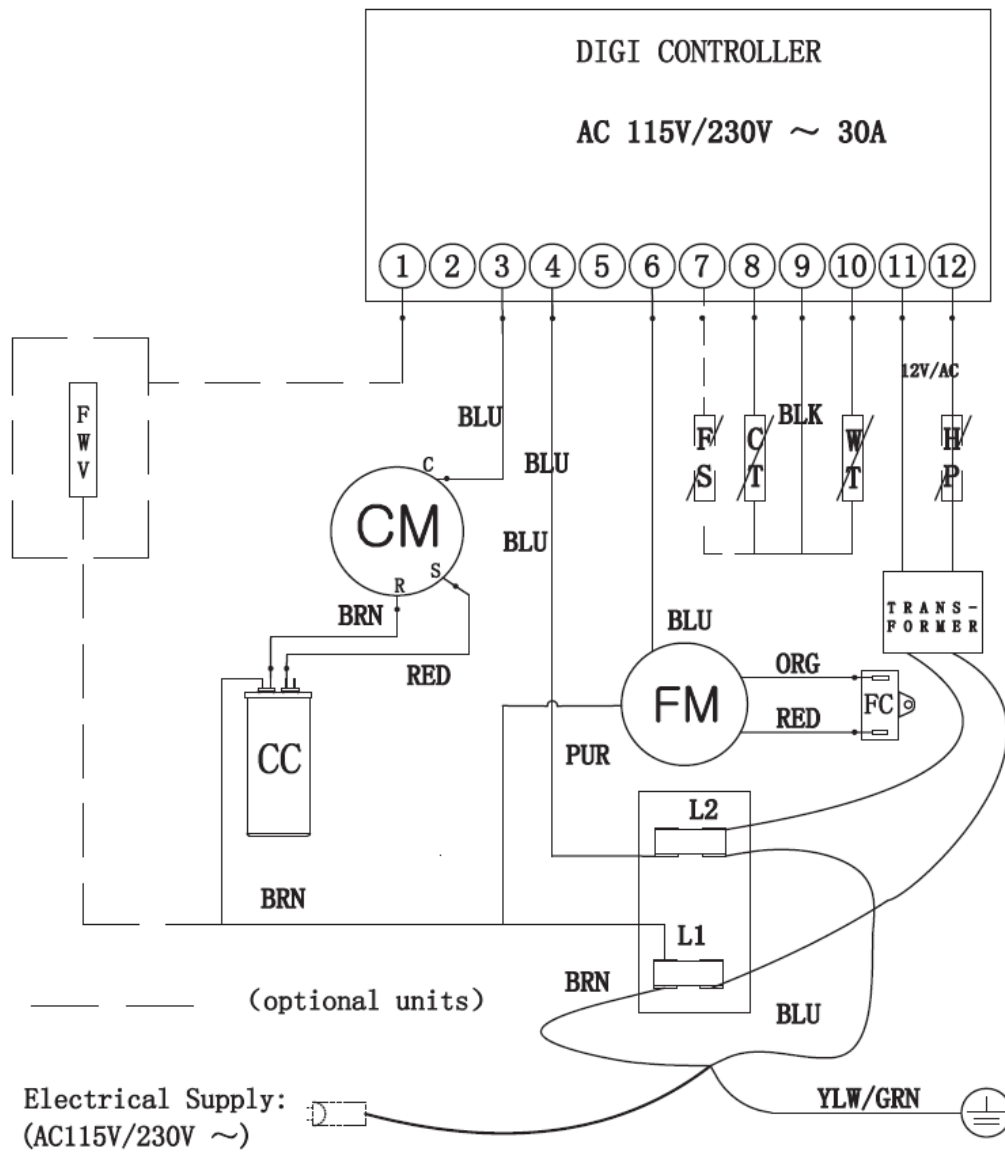

## 7 Specifications

### Technical data CIPU MINI pool heat pumps

MODEL		AR-HE-WP
* Performance at 80°F Air, 80% RH, 80°F Water		
Heating capacity	BTU/h	12500
Power consumption	KW	0.65
C.O.P.		5.4
* Performance at 80°F Air, 63% RH, 80°F Water		
Heating capacity	BTU/h	11600
Power consumption	KW	0.65
C.O.P.		5.0
* General data		
Compressor type		GMCC
Voltage	V	AC200-240V/1PH 50 or 60Hz
Rated current	A	3.2
Maximum current	A	4.0
ADVISED	SPA	2.4
VOLUME (m <sup>3</sup> )	POOL	9
Heat exchanger		Twist-titanium tube in PVC
Water pressure drop	Kpa	5
Water connection	mm	32-38mm (ID)
Fan quantity		1
Ventilation type		Horizontal
Air Flow	m <sup>3</sup> /h	1200
Power input of Fan	W	42
Noise level (1m)	dB(A)	47
Refrigerant (R410a or R32)	g	260
* Dimension/ Weight		
Net weight	kg	18
Gross weight	kg	20
Net dimension	mm	385*300*377
Packing dimension	mm	450*400*440

\*Above data are subjects to modification without notice.

We reserve the right to make technical and optical changes to the article in the course of product improvements.

## 8 Accessories & fitting

Accessories list

		
<p>Anti-vibration base, 4pcs</p>	<p>2 sets</p>	<p>2 sets</p>

## 9 Troubleshooting

Error code display on LED wire controller

Fault performance	Cause	Solution
No display	If power is cut If switch is off	Check power and switch
No working but display	IF the temperature setting in the stop range; If the heating mode is correct	Set the required temperature control value; Set the correct mode
Display unusual	Poor wiring or bindin; Sensor fault.	Good wiring and binding Check terminal or change sensor.
Large deference between display value and actual value	Un same location, Sensor deference.	Reliable location Adjust the value "CA" as "3.4.b"
No stopping	Error sensor location Electrical fault	Reliable location, Check electrical parts.
Over frequency starting	Value "d" set too least or higher ambient temperature	Adjust the value "d" as "3.4. a"
E1 or E2 displaying	Sensor short or open	Check sensor wire or change sensor.

## 10 Exploded Diagram

Exploded Diagram  
Model: AR-HE-WP

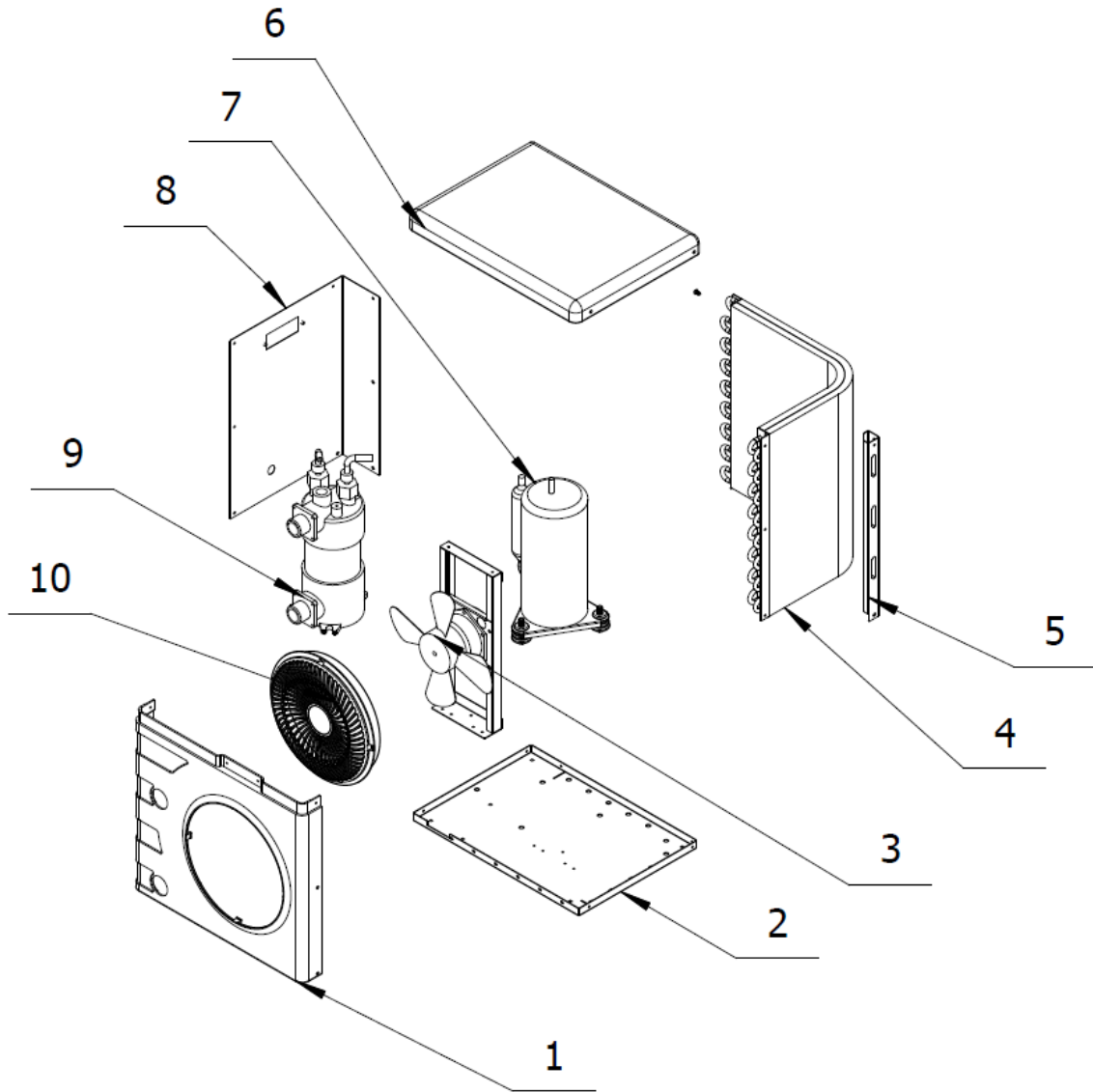

## 11 Maintenance

1	Front panel	2	Base panel
3	Fan & motor	4	Evaporator
5	Right bracket	6	Top panel
7	Compressor	8	Left panel
9	Titanium heat exchanger	10	Fan cover

## Maintenance

1. You should check the water supply system regularly to avoid the air entering the system and occurrence of low water flow, because it would reduce the performance and reliability of HP unit.
2. Clean your pools and filtration system regularly to avoid the damage of the unit as a result of the dirty or clogged filter.
3. You should discharge the water from bottom of water pump if HP unit will stop running for a long time (especially during the winter season).
4. In another way, you should check the unit is water fully before the unit start to run again.
5. After the unit is conditioned for the winter season, it is recommended to cover the heat pump with special winter heat pump.
6. When the unit is running, there is all the time a little water discharge under the unit

## 12 Service manual

### WARNING!

**Disposal, maintenance and repair work of the refrigerant circuit shall only be carried out in accordance with the manufacturer's specifications and by persons who possess a certificate of qualification.**

#### 1 Checks to the area

Prior to beginning work on systems containing flammable refrigerants or repairing to the refrigerating system, safety checks are necessary to ensure that the risk of ignition is minimised.

#### 2 Work procedure

Work shall be undertaken under a controlled procedure so as to minimise the risk of a flammable gas or vapor being present while the work is being performed.

#### 3 General work area

All maintenance staff and others working in the local area shall be instructed on the nature of work being carried out. Work in confined spaces shall be avoided. The area around the workspace shall be sectioned off. Ensure that the conditions within the area have been made safe by control of flammable material.

#### 4 Checking for presence of refrigerant

The area shall be checked with an appropriate refrigerant detector prior to and during work, to ensure the technician is aware of potentially toxic or flammable atmospheres. Ensure that the leak detection equipment being used is suitable for use with all applicable refrigerants, i.e. non-sparking, adequately sealed or intrinsically safe.

#### 5 Presence of fire extinguisher

If any hot work is to be conducted on the refrigeration equipment or any associated parts, appropriate fire extinguishing equipment shall be available to hand. Have a dry powder or CO2 fire extinguisher adjacent to the charging area.

#### 6 No ignition sources

No person carrying out work in relation to a refrigeration system which involves exposing any pipe work shall use any sources of ignition in such a manner that it may lead to the risk of fire or explosion. All possible ignition sources, including cigarette smoking, should be kept sufficiently far away from the site of installation, repairing, removing and disposal, during which refrigerant can



possibly be released to the surrounding space. Prior to work taking place, the area around the equipment is to be surveyed to make sure that there are no flammable hazards or ignition risks. “No Smoking” signs shall be displayed.

### **7 Ventilated area**

Ensure that the area is in the open or that it is adequately ventilated before breaking into the system or conducting any hot work. A degree of ventilation shall continue during the period that the work is carried out. The ventilation should safely disperse any released refrigerant and preferably expel it externally into the atmosphere.

### **8 Checks to the refrigeration equipment**

Where electrical components are being changed, they shall be fit for the purpose and to the correct specification. At all times the manufacturer’s maintenance and service guidelines shall be followed. If in doubt, consult the manufacturer’s technical department for assistance. The following checks shall be applied to installations using flammable refrigerants:

The charge size is in accordance with the room size within which the refrigerant containing parts are installed;

- the ventilation machinery and outlets are operating adequately and are not obstructed;
- if an indirect refrigerating circuit is being used, the secondary circuit shall be checked for the presence of refrigerant;
- marking to the equipment continues to be visible and legible. Markings and signs that are illegible shall be corrected;
- refrigeration pipe or components are installed in a position where they are unlikely to be exposed to any substance which may corrode refrigerant containing components, unless the components are constructed of materials which are inherently resistant to being corroded or are suitably protected against being so corroded.

### **9 Checks to electrical devices**

Repair and maintenance to electrical components shall include initial safety checks and component inspection procedures. If a fault exists that could compromise safety, then no electrical supply shall be connected to the circuit until it is satisfactorily dealt with. If the fault cannot be corrected immediately but it is necessary to continue operation, an adequate temporary solution shall be used. This shall be reported to the owner of the equipment, so all parties are advised.

#### **Initial safety checks shall include:**

- that capacitors are discharged: this shall be done in a safe manner to avoid possibility of sparking;
- that no live electrical components and wiring are exposed while charging, recovering or purging the system;
- that there is continuity of earth bonding.

### **10 Repairs to sealed components**

During repairs to sealed components, all electrical supplies shall be disconnected from the equipment being worked upon prior to any removal of sealed covers, etc. If it is absolutely necessary to have an electrical supply to equipment during servicing, then a permanently operating form of leak detection shall be located at the most critical point to warn of a potentially hazardous situation. Particular attention shall be paid to the following to ensure that by working on electrical components, the casing is not altered in such a way that the level of protection is affected. This shall include damage to cables, excessive number of connections, terminals not made to original specification, damage to seals, incorrect fitting of glands, etc.

Ensure that the apparatus is mounted securely.

Ensure that seals or sealing materials have not degraded to the point that they no longer serve the purpose of preventing the ingress of flammable atmospheres. Replacement parts shall be in accordance with the manufacturer’s specifications.

**NOTE** The use of silicon sealant can inhibit the effectiveness of some types of leak detection

equipment. Intrinsically safe components do not have to be isolated prior to working on them.

### **11 Repair to intrinsically safe components**

Do not apply any permanent inductive or capacitance loads to the circuit without ensuring that this will not exceed the permissible voltage and current permitted for the equipment in use.

Intrinsically safe components are the only types that can be worked on while live in the presence of a flammable atmosphere. The test apparatus shall be at the correct rating.

Replace components only with parts specified by the manufacturer. Other parts may result in the ignition of refrigerant in the atmosphere from a leak.

### **12 Cabling**

Check that cabling will not be subject to wear, corrosion, excessive pressure, vibration, sharp edges or any other adverse environmental effects. The check shall also take into account the effects of aging or continual vibration from sources such as compressors or fans.

### **13 Detection of flammable refrigerants**

Under no circumstances shall potential sources of ignition be used in the searching for or detection of refrigerant leaks. A halide torch (or any other detector using a naked flame) shall not be used.

### **14 Leak detection methods**

The following leak detection methods are deemed acceptable for all refrigerant systems. Electronic leak detectors may be used to detect refrigerant leaks but, in the case of flammable refrigerants, the sensitivity may not be adequate, or may need re-calibration.

(Detection equipment shall be calibrated in a refrigerant-free area.) Ensure that the detector is not a potential source of ignition and is suitable for the refrigerant used. Leak detection equipment shall be set at a percentage of the LFL of the refrigerant and shall be calibrated to the refrigerant employed, and the appropriate percentage of gas (25% maximum) is confirmed.

Leak detection fluids are suitable for use with most refrigerants but the use of detergents containing chlorine shall be avoided as the chlorine may react with the refrigerant and corrode the copper pipe-work.

If a leak is suspected, all naked flames shall be removed/extinguished.

If a leakage of refrigerant is found which requires brazing, all of the refrigerant shall be recovered from the system, or isolated (by means of shut off valves) in a part of the system remote from the leak. For appliances containing flammable refrigerants, oxygen free nitrogen (OFN) shall then be purged through the system both before and during the brazing process.

### **15 Removal and evacuation**

When breaking into the refrigerant circuit to make repairs – or for any other purpose – conventional procedures shall be used. However, for flammable refrigerants it is important that best practice is followed since flammability is a consideration. The following procedure shall be adhered to:

remove refrigerant;

purge the circuit with inert gas;

-evacuate;

-purge again with inert gas;

-open the circuit by cutting or brazing.

The refrigerant charge shall be recovered into the correct recovery cylinders. For appliances containing flammable refrigerants, the system shall be “flushed” with OFN to render the unit safe. This process may need to be repeated several times. Compressed air or oxygen shall not be used for purging refrigerant systems.

For appliances containing flammable refrigerants, flushing shall be achieved by breaking the vacuum in the system with OFN and continuing to fill until the working pressure is achieved, then venting to atmosphere, and finally pulling down to a vacuum. This process shall be repeated until no refrigerant is within the system. When the final OFN charge is used, the system shall be vented down to

atmospheric pressure to enable work to take place. This operation is absolutely vital if brazing operations on the pipe-work are to take place. Ensure that the outlet for the vacuum pump is not close to any ignition sources and that ventilation is available.

### **16 Charging procedures**

In addition to conventional charging procedures, the following requirements shall be followed.

-Ensure that contamination of different refrigerants does not occur when using charging equipment. Hoses or lines shall be as short as possible to minimize the amount of refrigerant contained in them.

-Cylinders shall be kept upright.

-Ensure that the refrigeration system is earthed prior to charging the system with refrigerant. Label the system when charging is complete(if not already).

-Extreme care shall be taken not to over fill the refrigeration system.

-Prior to recharging the system, it shall be pressure-tested with the appropriate purging gas.

The system shall be leak-tested on completion of charging but prior to commissioning. A follow up leak test shall be carried out prior to leaving the site.

### **17 Decommissioning**

Before carrying out this procedure, it is essential that the technician is completely familiar with the equipment and all its detail. It is recommended good practice that all refrigerants are recovered safely. Prior to the task being carried out, an oil and refrigerant sample shall be taken in case analysis is required prior to re-use of reclaimed refrigerant. It is essential that electrical power is available before the task is commenced.

a. Become familiar with the equipment and its operation.

b. Isolate system electrically.

c. Before attempting the procedure, ensure that:

- mechanical handling equipment is available, if required, for handling refrigerant cylinders;
- all personal protective equipment is available and being used correctly;
- the recovery process is supervised at all times by a competent person;
- recovery equipment and cylinders conform to the appropriate standards.

a. Pump down refrigerant system, if possible.

b. If a vacuum is not possible, make a manifold so that refrigerant can be removed from various parts of the system.

c. Make sure that cylinder is situated on the scales before recovery takes place.

d. Start the recovery machine and operate in accordance with manufacturer's instructions.

e. Do not overfill cylinders. (No more than 80 % volume liquid charge).

f. Do not exceed the maximum working pressure of the cylinder, even temporarily.

g. When the cylinders have been filled correctly and the process completed, make sure that the cylinders and the equipment are removed from site promptly and all isolation valves on the equipment are closed off.

h. Recovered refrigerant shall not be charged into another refrigeration system unless it has been cleaned and checked.

### **18 Labelling**

Equipment shall be labelled stating that it has been de-commissioned and emptied of refrigerant.

The label shall be dated and signed. For appliances containing flammable refrigerants, ensure that there are labels on the equipment stating the equipment contains flammable refrigerant.

### **19 Recovery**

When removing refrigerant from a system, either for servicing or decommissioning, it is recommended good practice that all refrigerants are removed safely.

When transferring refrigerant into cylinders, ensure that only appropriate refrigerant recovery cylinders are employed. Ensure that the correct number of cylinders for holding the total system charge are available. All cylinders to be used are designated for the recovered refrigerant and

labelled for that refrigerant (i.e. special cylinders for the recovery of refrigerant). Cylinders shall be complete with pressure-relief valve and associated shut-off valves in good working order. Empty recovery cylinders are evacuated and, if possible, cooled before recovery occurs.

The recovery equipment shall be in good working order with a set of instructions concerning the equipment that is at hand and shall be suitable for the recovery of all appropriate refrigerants including, when applicable, flammable refrigerants. In addition, a set of calibrated weighing scales shall be available and in good working order. Hoses shall be complete with leak-free disconnect couplings and in good condition. Before using the recovery machine, check that it is in satisfactory working order, has been properly maintained and that any associated electrical components are sealed to prevent ignition in the event of a refrigerant release. Consult manufacturer if in doubt. The recovered refrigerant shall be returned to the refrigerant supplier in the correct recovery cylinder, and the relevant waste transfer note arranged. Do not mix refrigerants in recovery units and especially not in cylinders.

If compressors or compressor oils are to be removed, ensure that they have been evacuated to an acceptable level to make certain that flammable refrigerant does not remain within the lubricant. The evacuation process shall be carried out prior to returning the compressor to the suppliers. Only electric heating to the compressor body shall be employed to accelerate this process. When oil is drained from a system, it shall be carried out safely.

## **20 Transport of equipment containing flammable refrigerants**

Determined by local regulations.

## **21 Disposal of equipment using flammable refrigerants**

See national regulations.

## **22 Storage of equipment/appliances**

The storage of equipment should be in accordance with the manufacturer's instructions.

## **23 Storage of packed (unsold) equipment**

Storage package protection should be constructed such that mechanical damage to the equipment inside the package will not cause a leak of the refrigerant charge.

The maximum number of pieces of equipment permitted to be stored together will be determined by local regulations.

## **24 Competence of service personnel**

### **General**

Special training additional to usual information for refrigerating appliance installation, repair, maintenance and decommission procedures is required when an appliance with flammable refrigerants is affected.

In many countries, the training of these procedures is carried out by national training organizations or manufacturers that are accredited to teach the relevant national competency standards that may be set in legislation.

The achieved competence should be documented by a certificate.

## **25 Training**

The training should include the substance of the following:

Information about the explosion potential of flammable refrigerants to show that flammables may be dangerous when handled without care.

Information about potential ignition sources, especially those that are not obvious, such as lighters, light switches, vacuum cleaners, electric heaters.

Information about the different safety concepts:

Unventilated – Safety of the appliance does not depend on ventilation of the housing.

Switching off the appliance or opening of the housing has no significant effect on the safety.

Nevertheless, it is possible that leaking refrigerant may accumulate inside the enclosure and flammable atmosphere will be released when the enclosure is opened.

Ventilated enclosure – Safety of the appliance depends on ventilation of the housing.

Switching off the appliance or opening of the enclosure has a significant effect on the safety. Care should be taken to ensure sufficient ventilation before.

Ventilated room – Safety of the appliance depends on the ventilation of the room. Switching off the appliance or opening of the housing has no significant effect on the safety. The ventilation of the room shall not be switched off during repair procedures.

Information about refrigerant detectors:

- Principle of function, including influences on the operation.
- Procedures, how to repair, check or replace a refrigerant detector or parts of it in a safe way.
- Procedures, how to disable a refrigerant detector in case of repair work on the refrigerant carrying parts.

Information about the concept of sealed components and sealed enclosures according to IEC60079-15:2010.

Information about the correct working procedures:

a. Commissioning

- Ensure that the floor area is sufficient for the refrigerant charge or that the ventilation duct is assembled in a correct manner.
- Connect the pipes and carry out a leak test before charging with refrigerant.
- Check safety equipment before putting in to service.

**Maintenance**

- Portable equipment shall be repaired outside or in a workshop specially equipped for servicing units with flammable refrigerants.
- Ensure sufficient ventilation at the repair place.
- Be aware that malfunction of the equipment may be caused by refrigerant loss and a refrigerant leak is possible.
- Discharge capacitors in a way that won't cause any spark. The standard procedure to short circuit the capacitor terminals usually creates sparks.
- Reassemble sealed enclosures accurately. If seals are worn, replace them.
- Check safety equipment before putting into service.

**Repair**

- Portable equipment shall be repaired outside or in a workshop specially equipped for servicing units with flammable refrigerants.
- Ensure sufficient ventilation at the repair place.
- Be aware that malfunction of the equipment may be caused by refrigerant loss and a refrigerant leak is possible.
- Discharge capacitors in a way that won't cause any spark.
- When brazing is required, the following procedures shall be carried out in the right order:
  - Remove the refrigerant. If the recovery is not required by national regulations, drain the refrigerant to the outside. Take care that the drained refrigerant will not cause any danger. In doubt, one person should guard the outlet. Take special care that drained refrigerant will not float back into the building.
  - Evacuate the refrigerant circuit.
  - Purge the refrigerant circuit with nitrogen for 5 min.
  - Evacuate again.
  - Remove parts to be replaced by cutting, not by flame.
  - Purge the braze point with nitrogen during the brazing procedure.
  - Carry out a leak test before charging with refrigerant. Reassemble sealed enclosures accurately. If seals are worn, replace them.
- Check safety equipment before putting into service.

### **Decommissioning**

- If the safety is affected when the equipment is putted out of service, the refrigerant charge shall be removed before decommissioning.
- Ensure sufficient ventilation at the equipment location.
- Be aware that malfunction of the equipment may be caused by refrigerant loss and a refrigerant leak is possible.
- Discharge capacitors in a way that won't cause any spark.
- Remove the refrigerant. If the recovery is not required by national regulations, drain the refrigerant to the outside. Take care that the drained refrigerant will not cause any danger. In doubt, one person should guard the outlet. Take special care that drained refrigerant will not float back into the building.
- Evacuate the refrigerant circuit.
- Purge the refrigerant circuit with nitrogen for 5min.
- Evacuate again.
- Fill with nitrogen up to atmospheric pressure.
- Put a label on the equipment that the refrigerant is removed.
- a. Disposal
  - Ensure sufficient ventilation at the working place.
  - Remove the refrigerant. If the recovery is not required by national regulations, drain the refrigerant to the outside. Take care that the drained refrigerant will not cause any danger. In doubt, one person should guard the outlet. Take special care that drained refrigerant will not float back into the building.
  - Evacuate the refrigerant circuit.
  - Purge the refrigerant circuit with nitrogen for 5min.
  - Evacuate again.
  - Cut out the compressor and drain the oil.
  - Evacuate the refrigerant circuit.
  - Purge the refrigerant circuit with nitrogen for 5min.
  - Evacuate again.
  - Cut out the compressor and drain the oil.

## 13 Environmentally friendly disposal

 **WARNING! Danger of suffocation!** Packaging material is dangerous for children. Never let children play with packaging material.

### Disposal and packaging

- The packaging of your unit consists of materials that are necessary to guarantee effective protection during transport. These materials are fully recyclable and therefore reduce the environmental impact. Dispose of the packaging in a bin for recyclable materials.

### Disposal of old equipment

- Old appliances must be disposed of in accordance with the guidelines and regulations of the local waste disposal authority. Check with your local administration for the address of the nearest recycling centre and deliver your appliance there.



The symbol of the crossed-out dustbin on a Waste electrical or electronic equipment indicates that it must not be disposed of with household waste at the end of its life. Collection points for waste electrical and electronic equipment are available free of charge in your area. You can obtain the addresses from your city or local government. You can find out about other return options created by us on our website [www.arebos.de](http://www.arebos.de).



The separate collection of Waste electrical or electronic equipment is intended to enable the reuse, recycling or other forms of recovery of Waste electrical or electronic equipment and to avoid the negative consequences of disposal on the environment and human health.

**Our customer service number: Tel. +44 (0) 208 068 5604**

**Fax: +49 (0) 931 4523 2799 / E-Mail: [info@arebos.de](mailto:info@arebos.de)**

Office address: Canbolat Vertriebs GmbH • Gneisenaustraße 10-11 • 97074 Würzburg

**Return address** can be found in the imprint: <https://www.arebos.de/impressum/>

Sales tax identification number: DE 263752326

Registration court in the commercial register is Würzburg, HRB 10082

WEEE-Reg. No. DE 61617071

## EU Declaration of Conformity



We, the

**Canbolat Vertriebsgesellschaft mbH**  
Gneisenaustraße 10-11  
97074 Würzburg  
Germany

declare in sole responsibility that the following product:

Brand

**AREBOS**

Product Name

Mini Heat Pump

Product Model

AR-HE-WP

Article Number

4252023110990

has been developed, constructed  
and manufactured in compliance  
with the requirements of the  
**European Directives:**

2014/30/EU

The object of the declaration described above is in conformity with the relevant European Union harmonization legislation.

The assessment is based on the  
following applied **harmonized  
standards:**

EN IEC 55014-1:2021  
EN IEC 61000-3-2:2019+A1:2021  
EN 61000-3-3:2013+A1:2019  
EN IEC 55014-2:2021

Other technical standards and  
specifications applied:

Place and date of issue:

Würzburg, 02.11.2022

Signature:

Dipl.-Inform. (Univ.) Korhan Canbolat, Managing Director

If the device is modified without our consent, this declaration of conformity loses its validity.