

Original instruction manual
Dumbbell set with rack - 18kg



Please observe all safety measures in this user manual to ensure safe use.

Table of contents

1 Introduction & safety instructions

2 Scope of delivery

3 Assembly instructions

4 Maintenance & care

5 Technical data

6 Environmentally friendly disposal

7 EU Declaration of Conformity

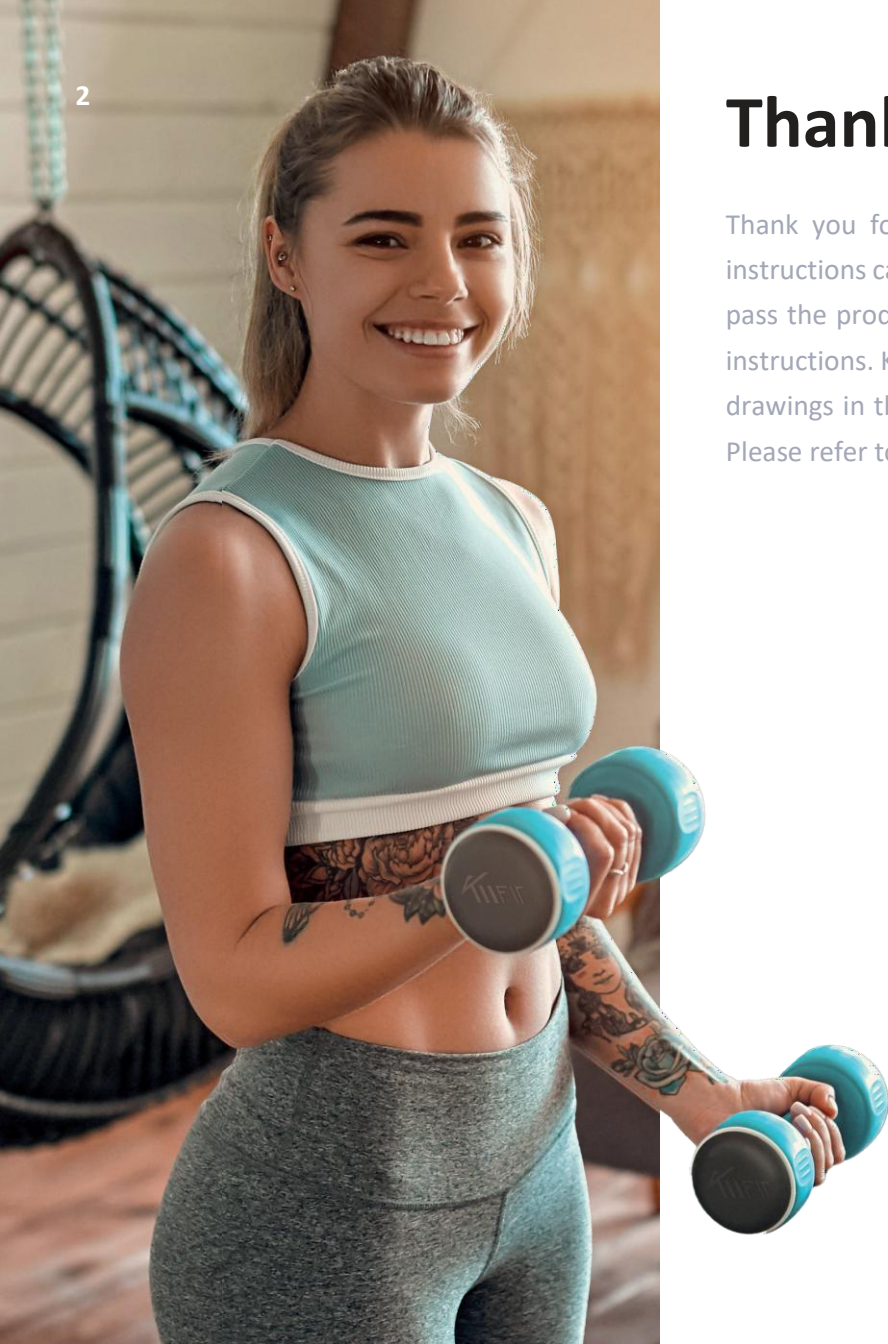

Thank you very much!

Thank you for purchasing our product. Please read the operating instructions carefully before using the product for the first time. If you pass the product on to a third party, you must also hand over these instructions. Keep the operating instructions for future reference. The drawings in this manual may not correspond to the physical objects. Please refer to the physical objects.



Important safety instructions

Your safety is of the utmost importance to us. Please read these instructions before commissioning and using the appliance. If you are unsure about the information contained in this brochure, please contact the dealer from whom you purchased your appliance.

- Do not carry the stand when it is loaded with dumbbells. Careless use can lead to serious injury.
- Keep children away from this product when they are unsupervised. The product is not intended for use by persons with reduced physical, sensory or mental capabilities, or lack of experience and knowledge, unless they have been given supervision or instruction concerning use of the product by a person responsible for their safety.
- Before starting an exercise programme, you should consult your doctor to determine whether you have any health or physical problems that could endanger your health and safety or prevent you from using the product properly. If you are taking medication that affects your heart rate, blood pressure or cholesterol levels, medical advice is essential.
- Incorrect or excessive exercise can be detrimental to your health. Stop exercising if you experience any of the following symptoms: pain, chest tightness, irregular or strong heartbeats, extreme shortness of breath, light-headedness, dizziness or nausea. If you experience any of these problems, you should consult your doctor before continuing with your exercise programme.



When using the product, you should always take basic safety precautions to reduce the risk of injury. This includes, for example



- For home and indoor use only.
- This product must be assembled by an adult.
- Always use the product on a firm, level surface.
- Do not use the product if parts are missing, damaged or worn.
- Check the product regularly for damage and wear. Stop using the product if it shows the first signs of damage or if parts come loose.
- It is the owner's responsibility to ensure that all users of the product are properly informed of all safety precautions. Check and tighten all parts regularly.
- It is recommended that you wear appropriate clothing when exercising. Do not wear loose-fitting clothing that can get caught.
- Always fully assemble the product before using it.





Original instruction manual
Dumbbell set with rack - 18kg

2

Scope of delivery

2x side parts / 5x rods / 10x screws / 1 x instruction manual / 2x5kg 2x3kg 2x1kg Hantel

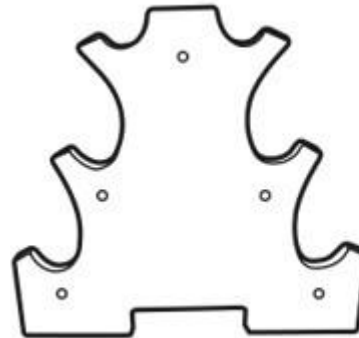

A (x 2)

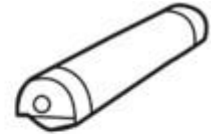

B (x 5)



C (x 10)

Nr.	Designation
A	Side parts (2x)
B	Bars (5x)
C	Screws (10x)

Assembly instructions & training tips

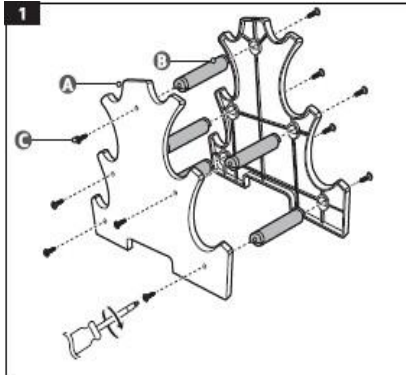

Step 1: Preparation

Lay out all the parts in front of you and make sure you have all the components:

The two side parts (A)

The four rods (B)

The screws (C)

A Phillips screwdriver (not shown, but necessary for the screws C)

Step 2: Insert the rods (B)

Take one of the side panels (A) and place the four rods (B) in the holes provided. The rods should sit firmly in the holes to ensure stability.

Step 3: Attach the second side panel (A)

Take the second side panel (A) and place it on the other side of the rods (B). Press it firmly so that the rods (B) also sit well in the holes of this side section. The two side sections (A) and the four rods (B) now form the basic structure of the shelf.

Step 4: Fix the side parts (A) with the screws (C)

Take the screws (C) and the Phillips screwdriver. Screw the screws (C) into the holes provided on the outside of the side parts (A). The screws (C) go through the holes in the side parts and into the bars (B) to firmly connect the parts together. Repeat this process until all screws (C) are firmly tightened. Take care not to overtighten the screws so as not to damage the material.

Once all the screws have been firmly tightened, the assembly is complete

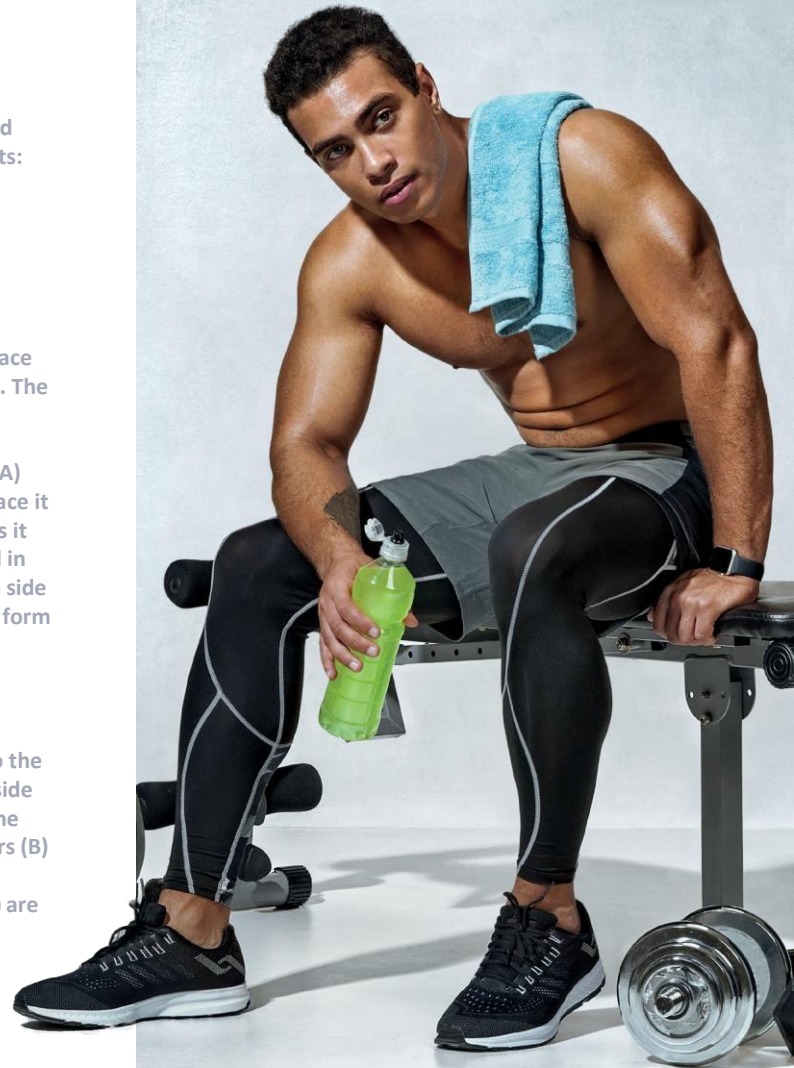
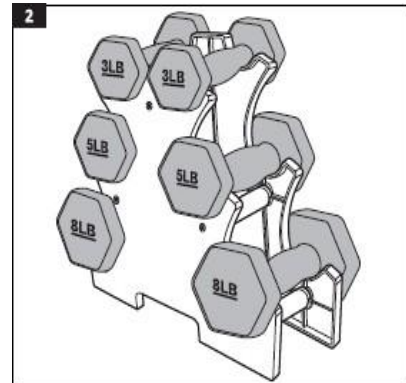



4

Maintenance & care

- Clean the product with a soft, slightly damp cloth.
- Never use corrosive cleaning agents or sharp objects for cleaning.
- Check regularly that all screws and bolts are tight.
- Store the product in a cool, dry place, out of the reach of children and pets

5

Technical data

Parameter	Wert
Model	IR92090-18kg
Max. Load capacity	500 kg
Structure Dimensions	40 x 40 x 25 cm
Weight	19 kg

We reserve the right to make technical and visual changes to the article in the course of product improvements.

Environmentally friendly disposal

⚠ Warning There is a risk of suffocation! The packaging material is dangerous for children. Never allow children to play with packaging material.

1. Disposal and packaging

The packaging of your device consists of materials that are necessary to ensure effective protection during transport. These materials are fully recyclable and therefore reduce the environmental impact. Dispose of the packaging in a recycling bin.

2. Disposal of old appliances

Old appliances must be disposed of in accordance with the guidelines and regulations of the local waste disposal authorities. Contact your local authority for the address of the nearest recycling centre and deliver your appliance there.



7

EU Declaration of Conformity

We,
KM-Fit by AREBOS GmbH, Industriestr. 24, 97297 Waldbüttelbrunn, Germany,

hereby declare that the device described below complies with the relevant basic safety and health requirements of the EU directives due to its design and construction and in the version placed on the market by us.

Productname: **Dumbbell set with rack - 18kg**
Modelnumber: **IR92090-18kg**
Article number: **4252023128407**

Testing is carried out on the basis of the following harmonised standards :

EN ISO 20957-1: 2024

EN ISO 20957-4: 2016

Other applied technical standards and specifications :

Place and date: Würzburg, 13.01.2026

Signature:



Dipl.-Inform. (Univ.)
Korhan Canbolat, Managing Director

If the device is modified without our consent, this declaration of conformity loses its validity.

Get in touch with us

Tel: +44 208 068 5604

Mail: info@km-fit.de

Company headquarters : KM-Fit - AREBOS GmbH • Industriestr. 24 • 97297 Waldbüttelbrunn

Please refer to the imprint for the return address: <https://www.km-fit.de>



km-fit.de